

ELECTRIC GAS PREHEATER

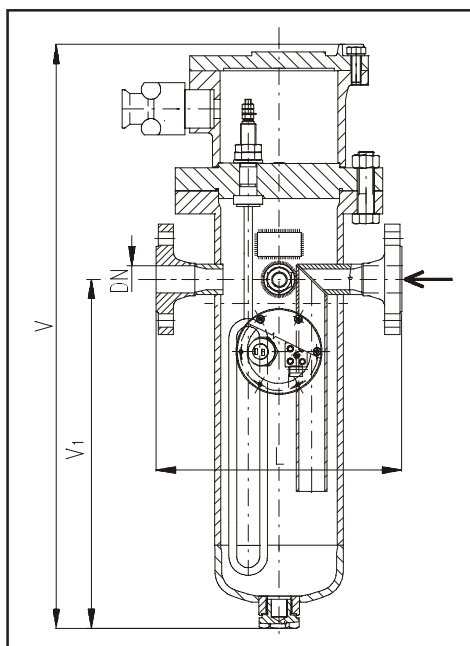

USE

A gas preheater with an electric heating is an equipment for the heating of a gaseous working fluid and especially it is used for an operation in gas regulating stations. Its suitable for natural gas and all noncorrosive gaseous media. If the preheater is a part of the gas control regulating station, it is necessary to follow "Regulations for an operation and a maintenance of regulating stations".

TYPES / DN / PN / TEMPERATURE RANGES

C26 628 440	DN 25	PN 40 or ANSI 300	to +70 °C.
C26 628 463	DN 25	PN 63	to +70 °C.

CONNECTION

Connecting dimensions correspond to DIN or ANSI.

MATERIAL

	C26 628 440, 463		
	DIN	ASTM	ČSN
Valve shell, socket pipes	St 45.8	Gr.B	12 022
Flanges, bottom, cover	H II	Gr.A	11 416
Sealing	NITRIL RUBBER		

TECHNICAL DESCRIPTION

The preheater consists of a pipe body with flange branches for an inlet and outlet of a substance heated. Two heating bodies are hung in an upper cover with an inlet. A supply cable is led through the inlet of the X2GT type. On the body there is from a side located a welded-on piece in which the non-rusting sump for the sensing unit PT100. The sensing unit is connected to the control electric regulation continuously regulating the outlet temperature of the gas from the electric preheater. On the body it is further attached an irreversible thermal fuse set to the temperature 72 °C. A thermostat with a breaking temperature 30 °C is situated in the cover together with the thermal fuse. In the case of a control with the regulator CRYTERM that is delivered by the SČA a.s. Ústí nad Labem, it is used the thermostat with the breaking temperature 60 °C. The cover of the interconnected space of preheater heating rods and the cover of the non-reversible thermal fuse and of a thermostat has the execution of a strong lock with a covering IP 64. The covering of the sensing unit PT100 in the sump is in the execution IP 67.

INSTALLATION

The preheater is mounted in a vertical position with the cover above located. The entry of the working fluid into the preheater is on the body designated by an arrow. An inlet piping must be before an installation perfectly freed from all the mechanical impurities. The connection of heating bodies, of the sensing unit PT100 and even of a thermal fuse can be carried out only by a professionally trained worker. Before connecting of the preheater on to the net it is necessary to check if during a transportation it did not come to the damage of electric parts. For securing of a safe operation it is necessary to pay an enhanced attention to a checking and a maintenance, especially to the parts that form a solid enclosure or a IP protection, including of cable inlets.

DIMENSION TABLE

PN	DN	L	V	V ₁	kW	kg
40	25	260	610	365	2	36,0
63	25	290	610	365	2	40,0

Note: The dimensions of connecting flanges - see pages 43, 44.